

Sunridge MCE Series – MCE-20A-G01 : 2.0mm Board-to-Board Coaxial Connector

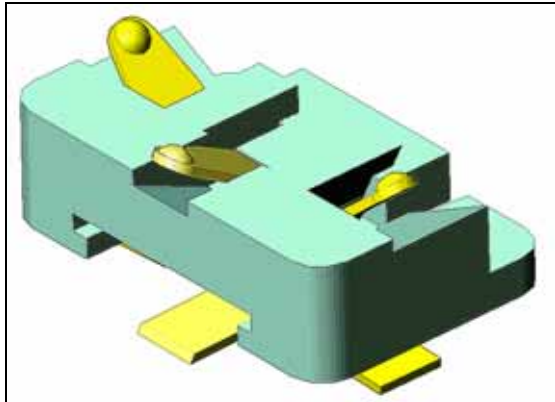

Sunridge MCE series coaxial connector offers an effective and reliable design solution for board-to-board RF signal transmission at the impedance of 50 OHM and the working frequency up to 6 GHz. It works as a mezzanine: the base section of the contact solders firmly to floor-board and the cantilever section makes solid contact to ceiling-board by spring load. MCE is ideal for OEM project where a module is to be integrated with the host board in production volume.



MCE-20A-G01 Product Summary:

MCE-20A-G01 connector, designed for 2.0mm board spacing, takes up a miniature footprint of 3.2mm x 4.5mm. The optimal spring load ensures sturdy connection with the compression pads. The contact frame is built into the insulator body, an integral structure that maximizes the physical strength and thus makes this product highly reliable. The insulator forms a protective cover, serving to shield the cantilever contact from the damage, which – after the connector is soldered on the board – could easily occur in handling or final assembly process. It also features a bottom support at 1.90mm height that safeguards the spring contact from overstrain by weight or excessive downward force. Among many other applications, MCE-20A-G01 can be readily incorporated into a GPS, WiFi or Telecommunication module that already has an EMI metal shield and a vertical board-stacking data I/O connector in its design platform.

■ Features

- Application: for 50 OHM, up to 6 GHz
- Prime Material: high strength copper alloy with gold plating for reliable spring contact; high temp plastic for IR reflow
- Space Economy: 3.2mm x 4.5mm foot print x 2.35mm height
- Stacking Height: 1.90mm to 2.15mm between two boards.
- Integral contact-insulator structure & robust spring force: solid compression contact, high reliability and optimal strength
- Minimal contact exposure: maximum protection
- Bottom support at 1.90mm height: prevent contact from overstrain by excess weight or push down.

■ Readily Available Options

(E-mail contact: engineering@sunridgecorp.com)

- Exposed-contact version: for prototype evaluation, manual soldering and visual inspection
- Bottom support at different height positions
- Request for engineering proposal welcome

■ Typical Application

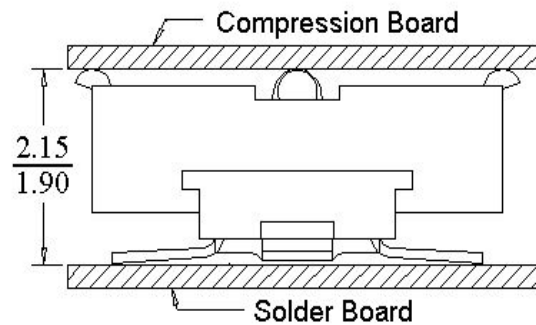
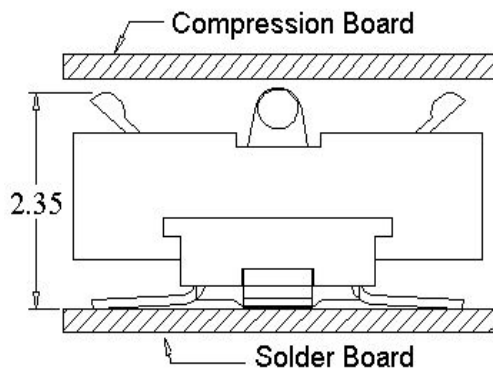
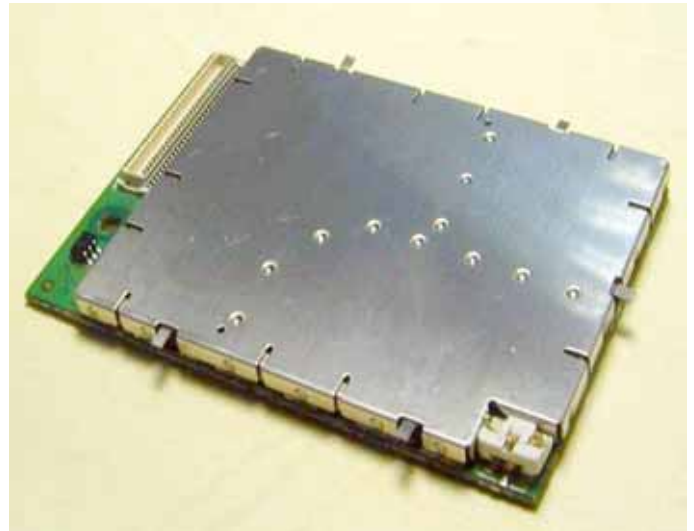

(dimension: mm)



www.sunridgecorp.com

Sunridge Corporation

USA Headquarters: 1-626-535-1780
Taiwan Operations: 886-2-2906-2119
E-mail: sales@sunridgecorp.com

Specialist in Interconnect Solutions



Sunridge MCE Series – MCE-20A-G01 : 2.0mm Board-to-Board Coaxial Connector



P/N: MCE-20A-G01

Form Factor:

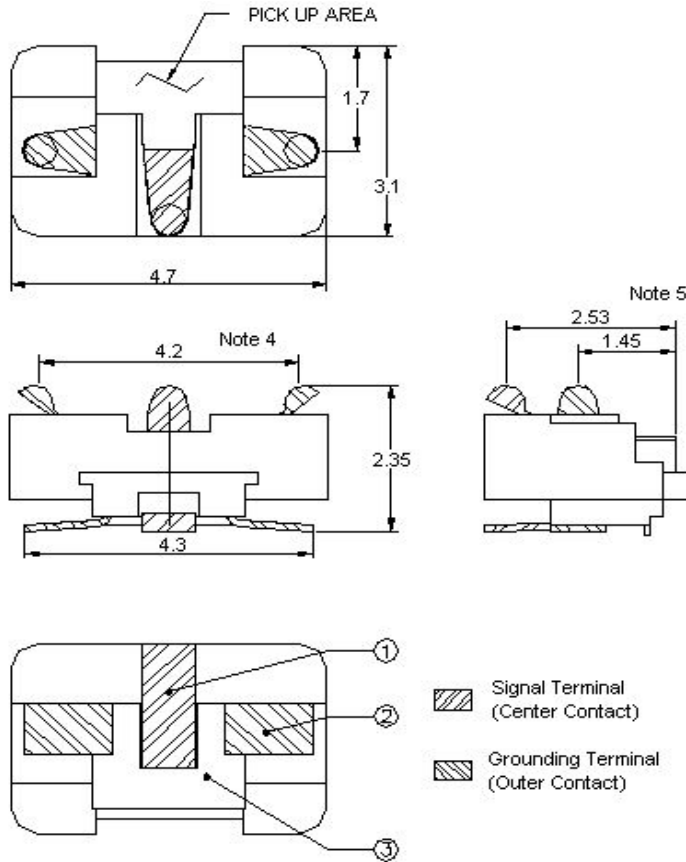

Notes:

1. Signal Terminal: Copper alloy, 50 u" nickel underplate, gold overall with 20 u" at contact areas
2. Ground Terminal: Copper alloy, 50 u" nickel underplate, gold overall with 20 u" at contact areas
3. Insulator: Engineering plastic, high temp grade for IR reflow
4. Contact Position (ref): 4.20mm; or, 4.60mm when compressed at 1.90mm height
5. Contact Position (ref): 2.53mm; or, 2.71mm when compressed at 1.90mm height

Characteristics	
Frequency Range	DC to 6GHz
Nominal Impedance	50 Ohm
Temperature Range	-40°C to +90°C
Voltage Rating	100 Vrms
Contact Resistance	50 m Ohm max
Withstanding Voltage	AC 350 Vrms
Insulation Resistance	3000 M Ohm min
Stacking Height	1.90 mm – 2.15 mm
Durability	10 Cycles

Recommended PCB Lay Out:

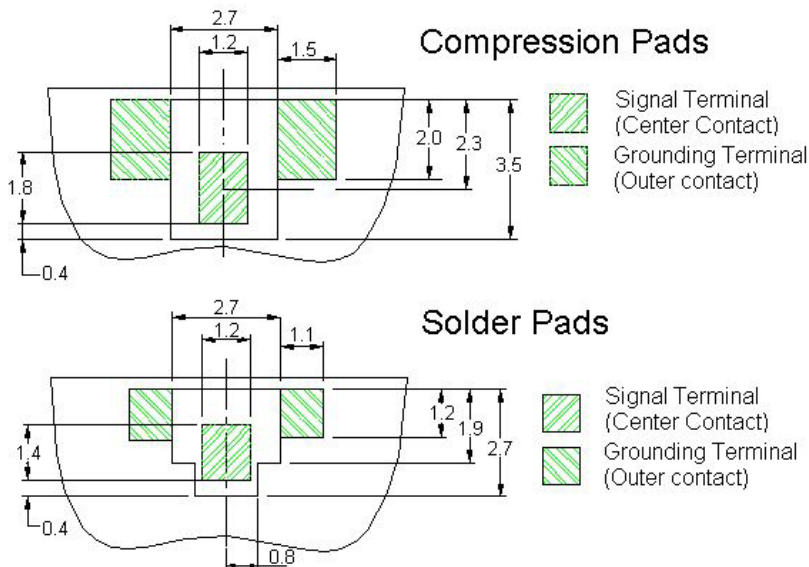

Application Note:

MCE connector is not intended to bear the mechanical load between two boards. For it to sustain the spring contact at 1.90mm to 2.15mm spacing, MCE-20A-G01 must be located within 10 mm from a structural component of sufficient strength.



www.sunridgecorp.com

(dimension: mm)

Sunridge Corporation

Specialist in Interconnect Solutions

USA Headquarters: 1-626-535-1780
 Taiwan Operations: 886-2-2906-2119
 E-mail: sales@sunridgecorp.com